

Optional Items

Description	Product Code
DP43C shelf	212192
DP63C shelf	212193
Temperature output terminal	281609
*N ₂ Gas Introduction Device 30L/min. (Factory Installed)	281151
*Vacuum Pump Switch (For DP43C/63C) (Factory Installed)	281152
Oil-sealed rotary vacuum pump	
GLD202BB with rubber hose kit 115V	GLD202BB115DPRKIT
GLD202BB with SUS hose kit 115V	GLD202BB115DPSKIT
GLD202BB with rubber hose kit 220V	GLD202BB220DPRKIT
GLD202BB with SUS hose kit 220V	GLD202BB220DPSKIT

* Please specify when ordering main unit.

Dimensions (Unit:mm)

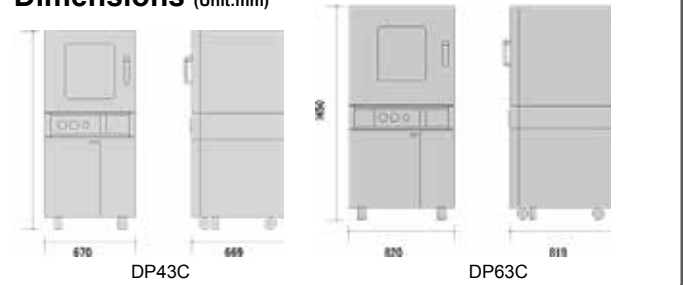

Sample Installation with CA801

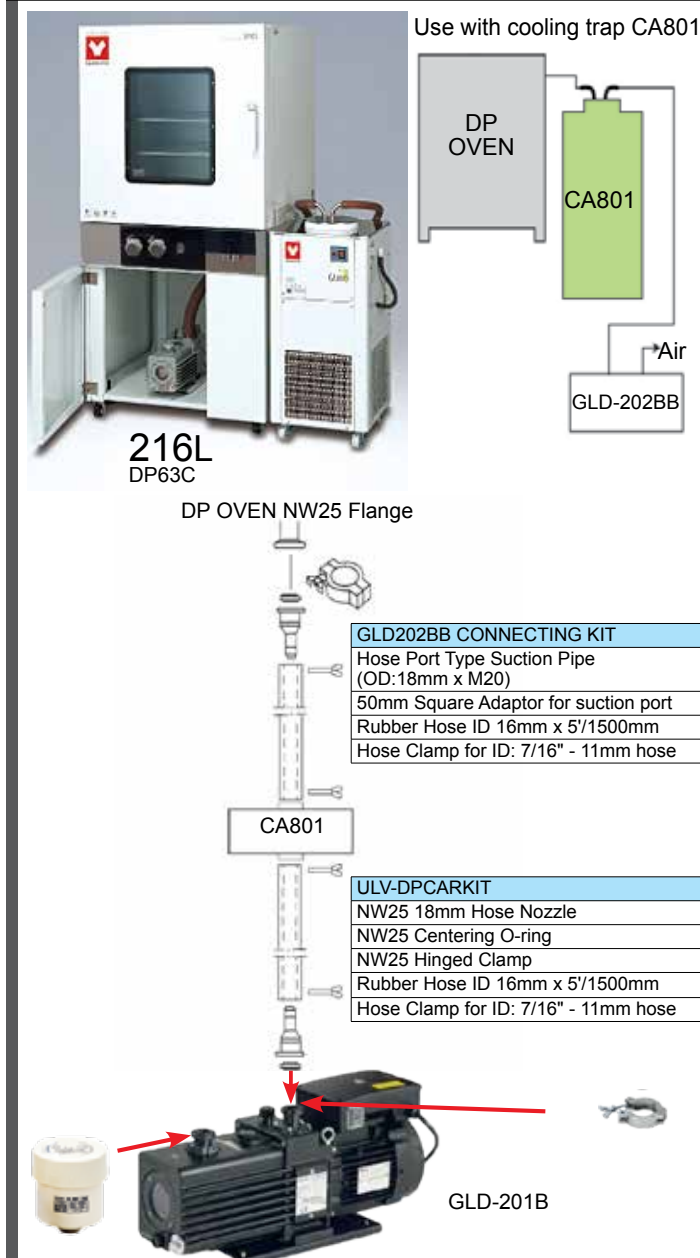

Rubber Hose or Stainless Steel Hose Connection for Vacuum Pump

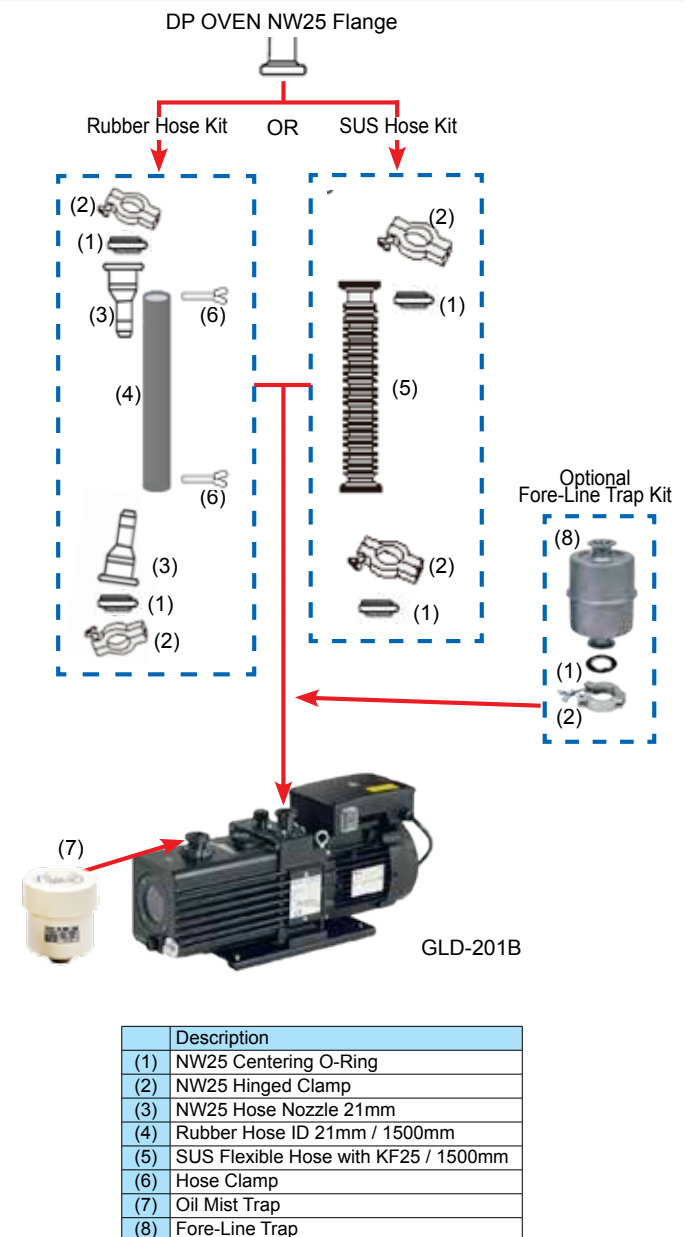

⚠ Attention

- Never use in flammable or explosive gas atmosphere
- Never use explosive or flammable material
- Caution: High temperature components